



TIGHTNESS CLASS



MATERIAL



BACTERIOSTATIC

# Distribution box

VCB160-12, VCB200-12, VCB160-12/90, VCB200-12/90

The Awenta PRO VCB160-12 and VCB200-12 distribution boxes enable the connection of up to 12 Ø75-90 mm ventilation ducts. Ducts not in use can be closed with the supplied end caps.

The box is available in two configurations of connection to the air handling unit: Ø160 mm and Ø200 mm.

The AWENTA PRO distribution boxes are equipped with a patented fixing system that enables precise adjustment of the distance between the box and the mounting planes and makes it easy to remove the box if necessary. Independently adjustable brackets allow the horizontal installation of the unit, enabling it to be tilted as well.

VCB series boxes are designed for installation in a heated area of the building; otherwise, they must be insulated with a layer of mineral wool (min. 15 cm). It can be permanently embedded into the screed or ceiling, or installed under plasterboards.



VCB160-12

VCB160-12/90



## AIR FLOW CHARACTERISTICS

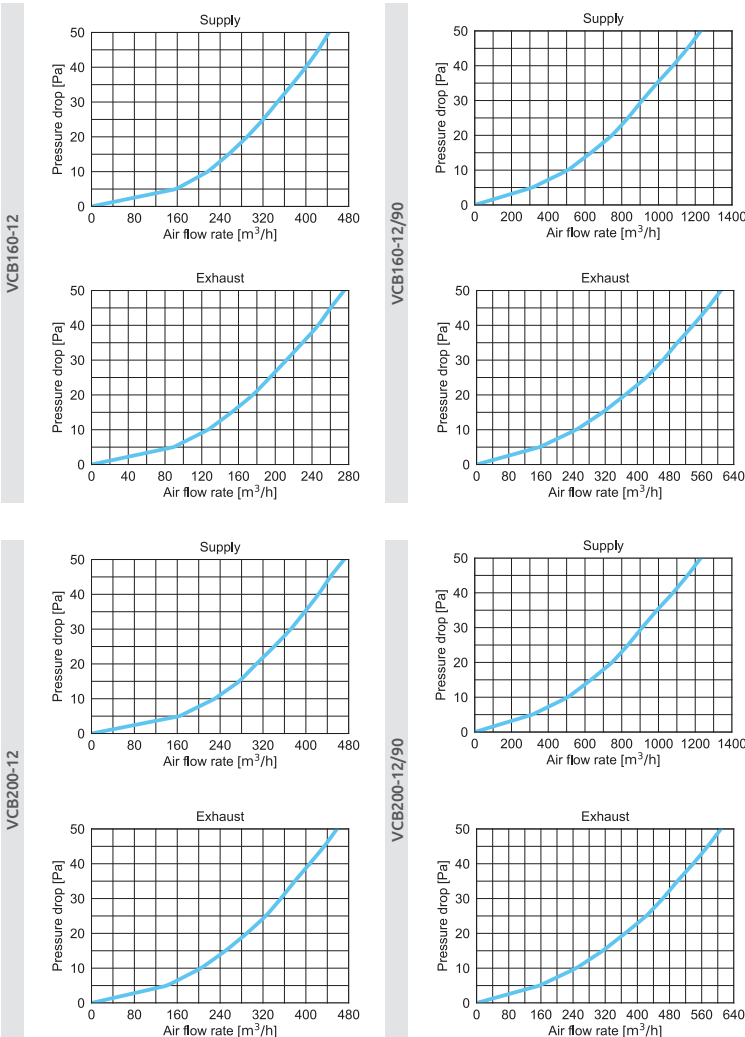

## DIMENSIONS

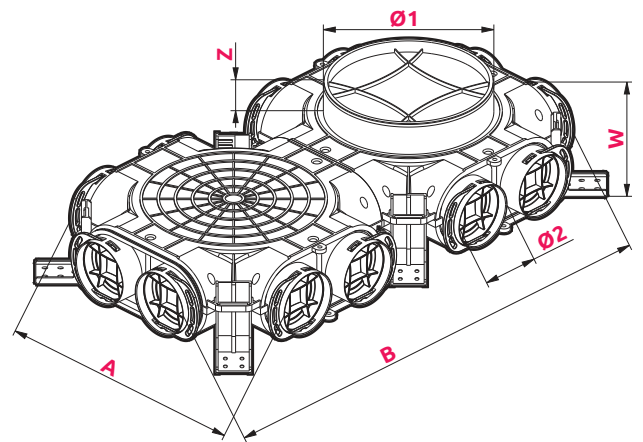

	Ø1	Ø2	A	B	W	Z
<b>VCB160-12</b>	160	75	347	639	104	38
<b>VCB200-12</b>	200	75	347	639	104	38
<b>VCB160-12/90</b>	160	90	407	697	104	38
<b>VCB200-12/90</b>	200	90	407	697	104	38

WITH **NANOSILVER** ADDITIVE  
ELIMINATING UP TO **99%** BACTERIA

